

Australian Capital Territory

## **Casino Control Approval (American Roulette) 2003 (No 2)\***

**Notifiable instrument NI2003— 506**

made under the

***Casino Control Act 1988, subsection 72(1) (Rules for authorised games)***

---

I approve the rules for the authorised game of “American Roulette” as set out in the attached schedule. The rules for the game of “American Roulette” notified in Notifiable instrument NI2003-20 are revoked.

Desmond Edward McKee  
Delegate  
ACT Gambling and Racing Commission  
10 December 2003

\*Name amended under Legislation Act 2001 s 60

# **SCHEDULE**

This is the accompanying schedule to the instrument of approval made under subsection 72(1) of the *Casino Control Act 1988* on 10 December 2003 by Desmond Edward McKee, Delegate of the ACT Gambling and Racing Commission.

# **CASINO CANBERRA LIMITED**

## **RULES OF AMERICAN ROULETTE**

## **AMERICAN ROULETTE INDEX**

### **TERMS USED IN AMERICAN ROULETTE**

- 1. AMERICAN ROULETTE TABLE**
- 2. AMERICAN ROULETTE WHEEL AND BALL**
- 3. MINIMUM AND MAXIMUM WAGERS**
- 4. WAGERS**
- 5. DEALING THE GAME**
- 6. PAYOUT ODDS**
- 7. SETTLEMENT OF WAGERS**
- 8. TABLE CLOSURE**
- 9. IRREGULARITIES**
- 10. GENERAL PROVISIONS**
- 11. RAPID ROULETTE**
- 12. SETTLEMENT OF RAPID ROULETTE WAGERS**
- 13. WAGERING PERIOD FOR RAPID ROULETTE**
- 14. RAPID ROULETTE ATS ACCOUNTS**
- 15. RAPID ROULETTE IRREGULARITIES**
- 16. TOUCH BET ROULETTE**
- 17. SETTLEMENT OF TOUCH BET ROULETTE WAGERS**
- 18. WAGERING PERIOD FOR TOUCH BET ROULETTE**
- 19. TOUCH BET ROULETTE ATS ACCOUNTS**
- 20. TOUCH BET ROULETTE IRREGULARITIES**

**APPENDIX A – THE AMERICAN ROULETTE (SINGLE ZERO) WHEEL**

**APPENDIX B – THE AMERICAN ROULETTE (DOUBLE ZERO) WHEEL**

**APPENDIX C – WAGERS ON AMERICAN ROULETTE**

**APPENDIX D – WAGERS ON THE RACE TRACK**

**APPENDIX E – AUTOMATED TOUCH SCREEN (ATS)**

## **TERMS USED IN AMERICAN ROULETTE**

The following words/terms when used in these rules shall have the following meaning unless the context clearly indicates otherwise.

### **Approved**

Means approved in writing by a Government Casino Inspector.

### **ATS**

An Automated Transaction Station featuring a touch screen monitor designed to allow a player to place wagers on a Rapid Roulette layout.

### **ATS Chip Account**

An Automated Transaction Station Chip Account is used to increase or decrease a patron's ATS chip account with electronic chips of a predetermined value according to buy-in, win or loss.

### **Ball**

An approved non-metallic Ball used in the game.

### **Casino Operator**

The organisation or person responsible for the conduct of gaming in the casino.

### **Casino Supervisor**

A person responsible for the supervision of the operation of the game.

### **Colour Chips**

Chips having a nominated value that may be used only at the table at which they were purchased.

### **Dealer**

A person responsible for the operation of the game.

### **Dolly**

A marker used to indicate the winning number.

### **Electronic Chips**

A virtual chip used on Rapid Roulette and Touch Bet game systems. All transactions using electronic chips are treated as per table gaming chips.

### **Marker Button**

A round object used to denote the value of colour chips when that value is higher than the table minimum.

### **Maximum Marker**

A pair of triangular objects of the same colour used to accept a maximum bet on a single number.

**Neighbour/Section Buttons**

Buttons that are used when making a wager on a number and its neighbouring numbers (eg. 3, 26, 0, 32, 15) or on sections of the wheel as described in rule 4.10.

**Race Track**

An area of the approved layout used for neighbour and section wagers.

**Round of Play**

That part of the game that commences when dolly is removed from the layout and concludes when the all payouts have been completed.

**Stake Buttons**

A pair of round objects of the same colour used to accept a cash wager on the even chances, columns and dozens.

**Void**

Neither the player nor the Dealer wins; any chips wagered or paid shall be returned.

**Wagering Period**

The period where the placement of wagers via the ATS of the Rapid Roulette game system is permitted.

**Wheel**

An approved apparatus used to determine the outcome of a game.

**Winning Number Display (WND)**

A device visible to players showing the outcome of recent spins of the Rapid Roulette game system.

## **AMERICAN ROULETTE**

### **1. AMERICAN ROULETTE TABLE**

- 1.1 An American Roulette table shall be approved prior to use.

### **2. AMERICAN ROULETTE WHEEL AND BALL**

- 2.1 An American Roulette wheel shall be approved prior to use. The numbers shall be arranged around the Wheel in accordance with either Appendix A or Appendix B.
- 2.2 Each Ball used in the game of American Roulette shall be approved prior to use.
- 2.3 The Ball may be changed at any time with the Casino Supervisor's approval.

### **3. MINIMUM AND MAXIMUM WAGERS**

- 3.1 The Casino Operator shall display the minimum and maximum wagers at the table and may change these limits provided that prior notice of the change is given to the players.
- 3.2 The Casino Operator may allow a player(s) to wager in excess of the stated maximum provided that a marker denoting the new limit(s) is placed adjacent to the player.
- 3.3 The multiples of wagers allowable shall be displayed at the table.
- 3.4 Wagers below the minimum shall be paid or collected and the owner of the wager shall be advised that further wagers under the minimum shall be returned.
- 3.5 Wagers above the displayed maximum shall be paid or collected to the maximum.



#### **4. WAGERS**

- 4.1 Prior to the announcing or displaying of “NO MORE BETS” each player shall be given the opportunity to place a wager.
- 4.2 All wagers shall be made by placing either gaming chips, Colour Chips, electronic chips, Stake Buttons or a Maximum Marker on the appropriate area(s) of the layout.
- 4.3 Where an approved Rapid Roulette or Touch Bet game system is used, wagers can only be made using an Automated Touch Screen (ATS).
- 4.4 The following wagers, as illustrated in Appendix C, are permitted:
- (a) Straight Up which is a wager on any one number, Double Zero or Zero;
  - (b) Split which is a wager on two numbers which are adjacent on the layout;
  - (c) Street which is a wager on three numbers which are adjacent in one row on the layout or Zero, 1 and 2 or Zero, 2 and 3 and where a Double Zero wheel is used, Zero, 1 and 2, or Zero, Double Zero and 2, or Double Zero, 2 and 3;
  - (d) Corner which is a wager on four numbers which are adjacent on the layout;
  - (e) Five-line which, where a Double Zero wheel is used, is a wager on five numbers, Zero, Double Zero, 1, 2 and 3;
  - (f) Six-line which is a wager on six numbers which are adjacent on the layout;
  - (g) Column which is a wager on twelve numbers which are adjacent in one column on the layout;
  - (h) Dozen which is a wager on twelve numbers in a particular dozen (1-12, 13-24, or 25-36);
  - (i) Low which is a wager on the numbers 1 – 18;
  - (j) High which is a wager on the numbers 19 – 36;
  - (k) Even which is a wager on all the even numbers;
  - (l) Odd which is a wager on all the odd numbers;
  - (m) Red which is a wager on all the red numbers around the wheel;
  - (n) Black which is a wager on all the black numbers around the wheel;  
and

- (o) Final which is a Straight Up wager at Touch Bet Roulette on numbers with the same last digit eg. 3, 13, 23, and 33 or 7, 17, and 27.
- 4.5 Once the "NO MORE BETS" has been announced or displayed no player shall handle, remove or alter the original wager, or place an additional wager, until a decision has been rendered and implemented on that wager.
- 4.6 Each player shall be responsible for the correct positioning of their wager/s regardless of whether or not they are assisted by the Dealer. It is each player's responsibility to ensure that any instructions given to the Dealer regarding the placement of wagers are correctly carried out.
- 4.7 The Casino Operator or its employees may require a player to use Colour Chips.
- 4.8 Where Stake Buttons are used, one button will be placed on the layout to represent the cash wager and the other button will stay with the cash until it can be counted. A Stake Button wager shall only be accepted if the exact money is tendered, subject to Rule 3.5.
- 4.9 A Maximum Marker may be used where a player requests to place the maximum wager on a single number and the combinations of that number. The Dealer shall place a marker for the wager on the layout and an identical marker with the correct amount of chips for that particular maximum wager on the perimeter of the wheel.
- 4.10 Where a Race Track or Neighbour/Section Buttons are used, wager/s requested by a player must be placed on the layout or on the appropriate area of the Race Track before "NO MORE BETS" is announced.

Wagers permitted on the Race Track or with Neighbour/Section Buttons, as illustrated in Appendix D, are:

- (a) Serie 5/8 - Tier (six piece wager);  
5/8, 10/11, 13/16, 23/24, 27/30 and 33/36.
- (b) Orphelins - Orphans (five piece wager);  
1, 6/9, 14/17, 17/20 and 31/34.
- (c) Serie 0/2/3 - Voisin de Zero (nine piece wager);  
0/2/3, 4/7, 12/15, 18/21, 19/22, 25/26/28/29 and 32/35
- (d) 0-Spel - Zero Game (four piece wager);  
0/3, 12/15, 26 and 32/35.
- (e) Voisins - Neighbours (five piece wager);  
a specific number with the two numbers either side of it on the Wheel.

## **5. DEALING THE GAME**

- 5.1 The Dealer shall spin the ball in the opposite direction to the rotation of the wheel.
- 5.2 The ball shall complete at least three revolutions around the track of the wheel to constitute a valid spin.
- 5.3 “NO MORE BETS” shall be:
- (a) announced and indicated by the Dealer prior to the ball coming to rest in the wheel, or
  - (b) where the Rapid Roulette and/or Touch Bet game systems are used, displayed on the ATS prior to the ball coming to rest in the wheel.
- 5.4 No person, other than a casino employee, shall, at any time, interfere with the wheel or the ball.

## **6. PAYOUT ODDS**

- 6.1 Winning wagers shall be paid as follows:

<b>WAGERS</b>	<b>PAYOUT ODDS</b>
(a) Straight up	35 to 1
(b) Split	17 to 1
(c) Street	11 to 1
(d) Corner	8 to 1
(e) Five line (Double Zero wheel only)	6 to 1
(f) Six line	5 to 1
(g) Column	2 to 1
(h) Dozen	2 to 1
(i) Low	1 to 1
(j) High	1 to 1
(k) Even	1 to 1
(l) Odd	1 to 1
(m) Red	1 to 1
(n) Black	1 to 1

## **7. SETTLEMENT OF WAGERS**

- 7.1 A wager shall win if the number in which the ball has come to rest is the number wagered on or is one of a combination of numbers wagered on.
- 7.2 Each wager shall be settled in accordance with its position on the layout when the ball falls to rest in a compartment of the wheel, subject to wagers placed in accordance with Rules 4.8, 4.9 and 4.10.

- 7.3 When the result is Zero or Double Zero:
- (a) wagers placed on Zero or Double Zero or on a combination of Zero and/or Double Zero with 1 and/or 2 and/or 3, shall win at odds in accordance with Rule 6.1; and
  - (b) all other wagers shall lose.

## **8. TABLE CLOSURE**

- 8.1 The hours of gaming shall be as determined under the provisions of the *Casino Control Act 1988*.
- 8.2 Subject to Rule 8.1, the Casino Operator may close any table before the close of gaming provided that notice is given to the players and a Government Casino Inspector if available.

## **9. IRREGULARITIES**

- 9.1 If the ball is spun in the same direction in which the wheel is rotating it is a void spin.
- 9.2 If the Dealer anticipates that the ball will not complete three revolutions around the track of the wheel, the Dealer shall announce "NO SPIN" and shall attempt to remove the ball from the wheel prior to its coming to rest in one of the compartments.
- 9.3 If a foreign object enters the wheel prior to the ball coming to rest, the spin is void.
- 9.4 If the ball fails to fall into one of the compartments, the spin is void.
- 9.5 If the ball is propelled or falls out of the wheel, the spin is void.

## **10. GENERAL PROVISIONS**

- 10.1 The casino operator may invalidate the outcome of a game if the game is disrupted by civil commotion, fire, riot, brawl, robbery, or an Act of God.
- 10.2 Where a person has contravened any provision of these rules, the Casino Operator may:
- (a) declare that any wager(s) made by the player(s) shall be void; and
  - (b) direct that the player(s) shall be excluded from further participation in the game.

- 10.3 The Casino Operator may invalidate a Round of Play if it is impractical to continue or a person(s) commits a fraudulent act that affects the outcome for that particular round.
- 10.4 Where the outcome of a Round of Play is invalidated, the Casino Operator may refund wagers made by players for that particular round.
- 10.5 The Casino Operator's decision shall be final in any dispute arising from, or not covered by, the provision of these rules, subject to a review by a ACT Gambling and Racing Commission, if requested.
- 10.6 An employee of the casino shall:
- (a) not advise a player on how to play, except to ensure compliance with these rules;
  - (b) not give or allow any advantage to a person, or cause to or allow a change in any probabilities of the game by any means other than that covered by these rules; and
  - (c) commensurate with their responsibilities, ensure that the game is conducted in accordance with the approved procedures.
- 10.7 A seated player who abstains from betting for three consecutive Rounds of Play whilst all other seats at that table are in use may be required to vacate that seat.
- 10.8 No onlooker or any player playing at any table may instruct or influence another player's decisions of play.
- 10.9 Players are not permitted to have side bets against each other.
- 10.10 A copy of these rules shall be made available, upon request.

## **11. RAPID ROULETTE**

- 11.1 A Rapid Roulette game system shall be approved prior to use.
- 11.2 Rapid Roulette is played on a virtual layout using electronic chips through an ATS chip account.

## **12. SETTLEMENT OF RAPID ROULETTE WAGERS**

- 12.1 Each wager will be settled electronically, by appropriate adjustment to a patron's ATS chip account, in accordance with payout odds relative to its position on the virtual layout when the ball falls to rest in a compartment of the wheel.

- 12.2 A minimum aggregate wager per spin may be set by the casino operator.
- 12.3 If by the end of the wagering period, a player has placed one or more wagers which are in aggregate less than the permitted aggregate wager (if any), those wagers will not be recognised by the ATS or the game system for the spin.

### **13. WAGERING PERIOD FOR RAPID ROULETTE**

- 13.1 The casino operator may determine how long the wagering period will be for the game.

### **14. RAPID ROULETTE ATS ACCOUNTS**

- 14.1 An ATS must display the active ATS chip account value.
- 14.2 A person wishing to play the game must buy in by either;
- (a) tendering to the Dealer an amount of cash, vouchers, authorised tokens or chips; or
  - (b) where the ATS has a note acceptor, placing an amount of cash directly into the note acceptor.

### **15. RAPID ROULETTE IRREGULARITIES**

- 15.1 If the ball comes to rest before the end of the wagering period, the spin is void.
- 15.2 The WND must be disregarded if the WND displays a number other than the actual outcome.
- 15.3 If an ATS experiences a malfunction prior to the expiry of the wagering period, the Dealer must void all wagers placed on the ATS for the relevant spin.
- 15.4 If an ATS experiences a malfunction on or after the expiry of the wagering period, the Dealer must seek to confirm what wagers were placed through the analysis of available records and cause the appropriate adjustments to be made.

- 15.5 If the game system (other than an ATS) experiences a malfunction (including by reason of physical damage) prior to the expiry of the wagering period, the Dealer must void all wagers placed by all players for the relevant spin.
- 15.6 If the game system (other than an ATS) experiences a malfunction (including by reason of physical damage) on or after the expiry of the wagering period, the Dealer must seek to confirm what wagers were placed through the analysis of available records and cause the appropriate adjustments to be made.
- 15.7 If the Dealer is unable, for the purposes of Rules 15.6, to confirm the relevant wagers placed through the analysis of available records, the Dealer must void those wagers.

## **16. TOUCH BET ROULETTE**

- 16.1 A Touch Bet Roulette game system shall be approved prior to use.
- 16.2 Touch Bet Roulette is played on a virtual layout using electronic chips through an ATS chip account.

## **17. SETTLEMENT OF TOUCH BET ROULETTE WAGERS**

- 17.1 Each wager will be settled electronically, by appropriate adjustment to a patron's ATS chip account, in accordance with payout odds relative to its position on the virtual layout when the ball falls to rest in a compartment of the wheel.
- 17.2 A minimum aggregate wager per spin may be set by the casino operator.
- 17.3 If by the end of the wagering period, a player has placed one or more wagers which are in aggregate less than the permitted aggregate wager (if any), those wagers will not be recognised by the ATS or the game system for the spin.

## **18. WAGERING PERIOD FOR TOUCH BET ROULETTE**

- 18.1 The wagering period of Touch Bet Roulette will be determined by the rate of the spin of the ball on the live gaming table.

## **19. TOUCH BET ROULETTE ATS ACCOUNTS**

- 19.1 An ATS must display the active ATS chip account value.

- 19.2 A person wishing to play the game must buy in by placing an amount of cash directly into the note acceptor.
- 19.3 A person wishing to cash out must press the appropriate button on the ATS and a printed voucher will be dispensed. This voucher is to be presented at the Cash Desk for redemption.

## **20. TOUCH BET ROULETTE IRREGULARITIES**

- 20.1 If the ball comes to rest before the end of the wagering period, the spin is void.
- 20.2 The WND must be disregarded if the WND displays a number other than the actual outcome.
- 20.3 If an ATS experiences a malfunction prior to the expiry of the wagering period, the Dealer must void all wagers placed on the ATS for the relevant spin.
- 20.4 If an ATS experiences a malfunction on or after the expiry of the wagering period, the Dealer must seek to confirm what wagers were placed through the analysis of available records and cause the appropriate adjustments to be made.
- 20.5 If the game system (other than an ATS) experiences a malfunction (including by reason of physical damage) prior to the expiry of the wagering period, the Dealer must void all wagers placed by all players for the relevant spin.
- 20.6 If the game system (other than an ATS) experiences a malfunction (including by reason of physical damage) on or after the expiry of the wagering period, the Dealer must seek to confirm what wagers were placed through the analysis of available records and cause the appropriate adjustments to be made.
- 20.7 If the Dealer is unable, for the purposes of Rules 20.6, to confirm the relevant wagers placed through the analysis of available records, the Dealer must void those wagers.



APPENDIX A

The American Roulette (Single Zero) Wheel

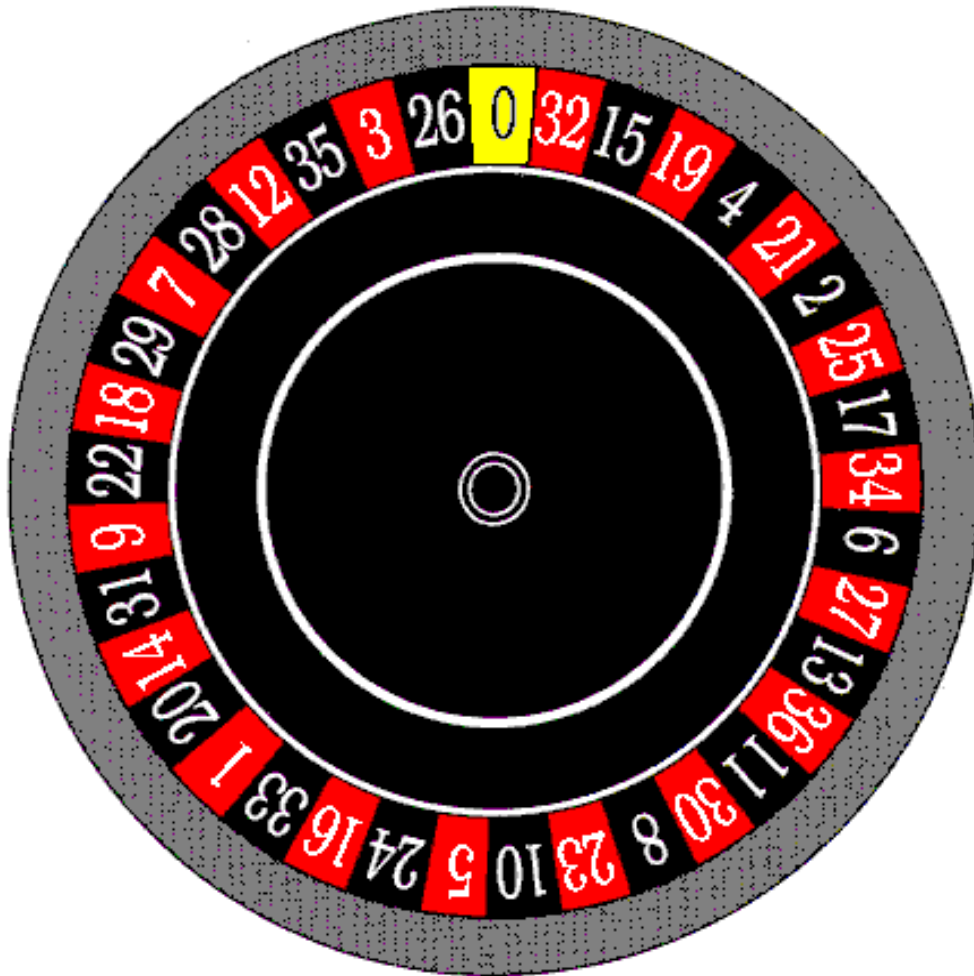

APPENDIX B

American Roulette (Double Zero) Wheel

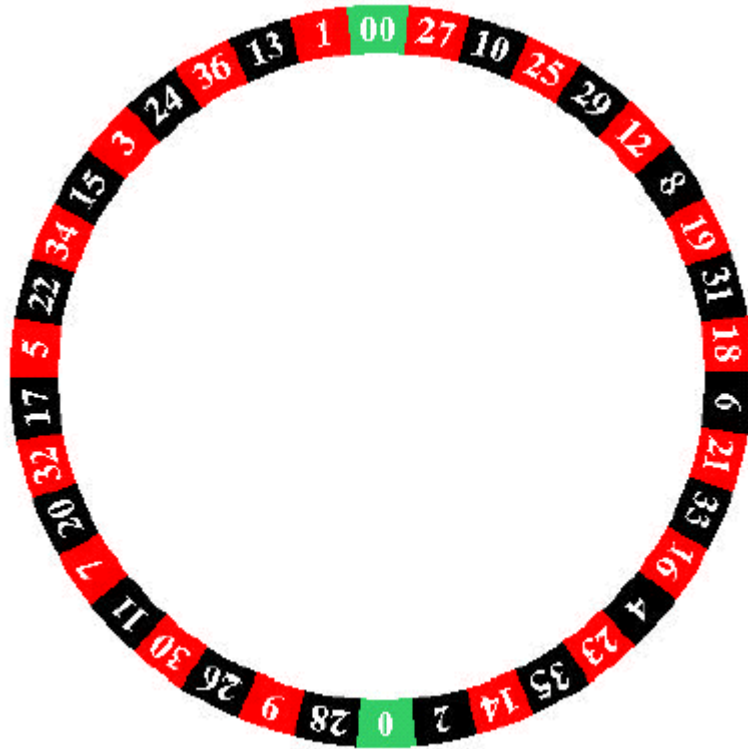

APPENDIX C

Wagers on American Roulette

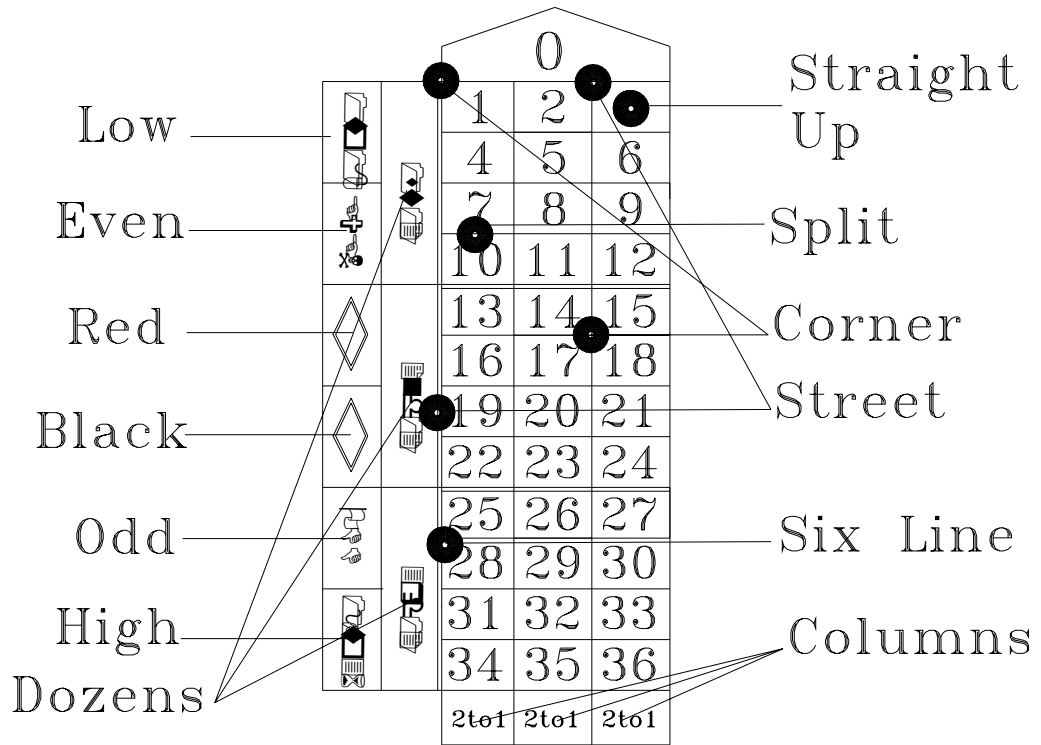



APPENDIX E

Automated Touch Screen (ATS)

